



SPP

*Southwest
Power Pool*

**Facility Study
For
Generation Interconnection
Request
GEN-2011-044**

*SPP Generation
Interconnection Studies*

(#GEN-2011-044)

January 2014

Revision History

Date	Author	Change Description
01/08/2013	SPP	Facility Study Report Issued

Summary

ITC Great Plains (ITCGP) performed a detailed Facility Study at the request of Southwest Power Pool (SPP) for Generation Interconnection request GEN-2011-044 (149.5 MW/Wind) located in Barber County in Kansas. The originally proposed in-service date for GEN-2011-044 was December 31, 2013. SPP has proposed the in-service date will be after the assigned Interconnection Facilities Upgrades and Shared Network Upgrades are completed. The request for interconnection was placed with SPP in accordance with SPP's Open Access Transmission Tariff, which covers new generation interconnections on SPP's transmission system.

Phases of Interconnection Service

It is not expected that interconnection service will require phases however, interconnection service will not be available until all interconnection facilities and network upgrades can be placed in service.

Interconnection Customer Interconnection Facilities

The Interconnection Customer will be responsible for all of the transmission facilities connecting the customer owned substation to the Point of Interconnection (POI), at the planned ITC Great Plains Thistle Substation on 345kV bus. This planned Thistle 345kV Substation is part of SPP Priority Projects, which have a scheduled in-service of December 31, 2014. The new ITCGP Thistle substation will be owned and operated by ITC Great Plains (ITCGP). The Customer will also be responsible for any equipment located at the Customer substation necessary to maintain a power factor of 0.95 lagging to 0.95 leading at the POI.

Transmission Owner Interconnection Facilities and Non-Shared Network Upgrades

To allow interconnection the Transmission Owner will need to do some relay work. If GEN-2011-043 withdraws, then to allow interconnection the Transmission Owner will need construct a new rung, two new 345kV breakers, and associated equipment for acceptance of the Interconnection Customer's Interconnection Facilities at an estimated cost of \$4,023,332.00. Currently, the costs for the new breaker position and associated terminal equipment are assigned to GEN-2011-043. GEN-2011-043 and GEN-2011-044 are planned to utilize one 345kV generator lead from the Interconnection Customer substation to ITCGP Thistle Substation. At this time GEN-2011-044 is responsible for \$50,000.00 (2013 dollars) of Transmission Owner Interconnection Facilities and Non-Shared Network Upgrades.

Shared Network Upgrades

The interconnection customer was studied within the DISIS-2011-002 Impact Study. At this time, the Interconnection Customer is allocated \$9,021,096.30 for Shared Network Upgrades. If higher queued interconnection customers withdraw from the queue, suspend or terminate their GIA, restudies will have to be conducted to determine the Interconnection Customers' allocation of Shared Network Upgrades. All studies have been conducted on the basis of higher queued interconnection requests and the upgrades associated with those higher queued interconnection requests being placed in service. At

this time, the Interconnection Customer is allocated the following cost for Shared Network Upgrade:

Share Network Upgrade Description	Allocated Cost	Total Cost
GEN-2011-017 Tap – Mullergren 345kV circuit #1 – Build approximately 55 miles of 345kV from GEN-2011-017 Tap – New Mullergren 345kV Substation at 3000 amps.	\$6,044,134.52	\$67,000,000.00
Mullergren 345/230/13kV Transformer circuit #1 – Build new 345/230/13kV transformer at new Mullergren 345/230kV substation.	\$721,687.70	\$8,000,000.00
Mullergren 345/230kV Substation – Build new 345/230kV substation terminating GEN-2011-017 Tap - Mullergren 345kV line, Mullergren 345/230/13kV Transformer, and Mullergren - Great Bend 230kV.	\$2,255,274.08	\$25,000,000.00
Total	\$9,021,096.30	

Other Network Upgrades

Certain Other Network Upgrades are not the cost responsibility of the Customer but will be required for full Interconnection Service. These Other Network Upgrades include:

1. Beaver County – Buckner 345kV circuit #1, assigned to DISIS-2011-001 Customers
2. Hitchland – Woodward 345kV double circuit, scheduled for 6/30/2014 in-service
3. Hitchland 345/230kV Autotransformer circuit #2, scheduled for 6/30/2014
4. Mathewson Substation and Tatonga – Mathewson – Cimarron circuit #2, assigned to DISIS-2011-001 Customers
5. Spearville – Clark – Thistle – Wichita 345kV double circuit, scheduled for 12/31/2014 in-service
6. Thistle 345/138/13kV transformer circuit #1, scheduled for 12/31/2014 in-service
7. Thistle – Flat Ridge 138kV circuit #1, scheduled for 12/31/2014 in-service
8. TUCO Interchange 345/230/13.2kV Autotransformer circuit #2, scheduled for 3/31/2013 in-service
9. TUCO Interchange – Border – Woodward 345kV circuit #1, scheduled for 5/19/2014 in-service
10. Woodward - Thistle 345kV double circuit, scheduled for 12/31/2014 in-service
11. Woodward 345/138kV transformer circuit #2, scheduled for 5/19/2014 in-service

Depending upon the status of higher or equally queued customers, the Interconnection Customer’s in-service date is at risk of being delayed or their Interconnection Service is at risk of being reduced until the in-service date of these Other Network Upgrades.

Conclusion

Interconnection Service for GEN-2011-044 will be delayed until the Transmission Owner Interconnection Facilities Shared Network Upgrades are constructed. The Customer is responsible for \$50,000.00 (2013 dollars) of Transmission Owner Interconnection Facilities and Non-Shared Network Upgrades. At this time, the Interconnection Customer is allocated \$9,021,096.30 for Shared Network Upgrades. After all Interconnection Facilities and Network Upgrades have been placed into service, Interconnection Service for 149.5

MW, as requested by GEN-2011-044, can be allowed. At this time the total allocation of costs assigned to GEN-2011-044 for Interconnection Service are estimated at \$9,071,096.30.

**Generation Interconnection Facilities Study Report
for GEN 2011-044 – 149.5 MW Wind Generating Facility
In Barber County, Kansas.
June 4, 2013**



Table of Contents

1.0 Overview3

 1.1 Facility Study Summary3

2.0 Voltage Requirements4

3.0 Network Upgrades.....4

4.0 Transmission Owner Interconnection Facilities9

5.0 Interconnection Customer Interconnection Facilities11

6.0 Right of Way Requirements.....11

1.0 Overview

ITC Great Plains (“ITCGP”) has performed a facility study at the request of Southwest Power Pool (“SPP”) for Generation Interconnection request GEN-2011-044 under the SPP Open Access Transmission Tariff. The subject request entails interconnecting a 149.5 MW wind powered generation facility in Barber County, Kansas. It is proposed to be in service by December 31, 2013.

The ITCGP scope of this facility study is to provide a cost estimate for the Customer’s interconnection facilities. This study does not directly address any of the network upgrades that may be identified in the DISIS, the facilities that are being constructed by the interconnection customer, or any potential sub-transmission facilities (if any) that may be required.

Please note that this project will interconnect at the Thistle substation along with the 149.5 MW wind farm GEN 2011-043 through a common lead line. The network upgrades and transmission owner interconnection facilities at the Thistle substation mentioned in this report have been sized for both GEN 2011-043 and GEN 2011-044. However, even in the event that either of the two interconnection requests is withdrawn, the network upgrades and interconnection facilities listed in this report will still be valid and required.

1.1 Facility Study Summary

ITCGP estimates the total project cost of the customer’s interconnection facilities will be **\$ 4,023,332** (+/- 20 % accuracy) including applicable company overheads and potential tax gross ups in 2013 dollars. It includes **\$ 3,281,619** for Network Upgrades and **\$ 741,713** for Transmission Owner Interconnection Facilities. It is further estimated that the required legal/real estate acquisition and construction activities will require approximately 24 months after the GIA is executed. This report contains additional details regarding the estimate as well as results of short circuit studies, review of reactive compensation, and information on Interconnection & Operating requirements.

The GEN 2011-044 interconnection facilities will require Network Upgrades on the ITCGP system to connect the new generation. Network Upgrades consist of adding (2) 345kV breakers and associated disconnects at the Thistle substation.

In addition to the identified Network Upgrades, there are specific Interconnection Facilities which ITCGP will construct, own, operate, and maintain. These facilities include the new line entrance structure and 345kV disconnect switch on the end of the radial line from GEN 2011-044 at the Thistle substation as well as any ITCGP relaying and control equipment required for the protection of the developer’s radial line.

The Interconnection Customer is responsible for constructing all sole-use facilities such as the wind farm collector station and the radial 345kV line from the collector station to the Thistle substation. While this report does define Interconnection Customer owned Interconnection Facilities in enough detail to explain basic requirements, it does not define or contain all of the detailed requirements. Additional metering, communications, and operational requirements may be identified as the Interconnection and Operating Agreements are developed and further communications between the Transmission Owner and Interconnection Customer take place. The Interconnection Customer’s low voltage system is not defined in this report.

2.0 Voltage Guidelines:

Reactive power, voltage regulation and operating requirements will be as per Transmission Operator (TOP) and Transmission Provider directives. Interconnection Customer will operate the generating facility to a voltage schedule of 354 kV (1.026 pu) with a bandwidth of +/- 6 kV (0.017 pu) at the Point of Interconnection (POI) utilizing the Generating Facility's required power factor design capability as indicated in SPP DISIS-2011-002-2. As per SPP DISIS 2011-002-2, the Interconnection Customer's required power factor capability is 0.95 lagging to 0.95 leading (at the POI).

For further clarification, the Interconnection Customer may meet the +/- 0.95 power factor requirement by utilizing reactive capability from the wind generators or by adding external reactive compensation. Note that any reactive compensation installed by the Interconnection Customer shall not cause voltage distortion in accordance with Article 9.7.6 Power Quality of the Generation Interconnection Agreement.

The Interconnection Customer will regulate the Generating Facility's voltage to the specified voltage set-point within the defined bandwidth stated above using an automatic voltage controller utilizing the inherent reactive power capability in the wind turbines and if applicable external reactive compensation.

The above voltage schedule is subject to change. If the need for a change is identified, it will be done within the limits of the GIA provisions stated in Section 9.6 and the Generating Facility's power factor design criteria as stated above. If a schedule change is needed, appropriate written documentation of the change will be provided to the Interconnection Customer.

The Interconnection Customer is required to have a generator operator available for 24/7 communication with the TOP. The TOP may, at any time request a variance from the schedule in response to system operating/security requirements.

3.0 Network Upgrades

3.0.1 Project Location:

The generation facility will interconnect at the Thistle substation located in Barber County, Kansas.

3.0.2 Project Overview:

The purpose of this project is to add two 345 kV breakers and associated disconnects at the Thistle substation to provide a transmission system interconnection for the GEN 2011-044 wind farm.

3.0.3 Design Criteria:

The Transmission Owner's standards will be applicable. Where no applicable standards are available, the Transmission Owner will substitute industry standards and other good utility practices.

3.0.4 One-Line Diagrams:
See Figure 1 for Transmission Owner One-Line.

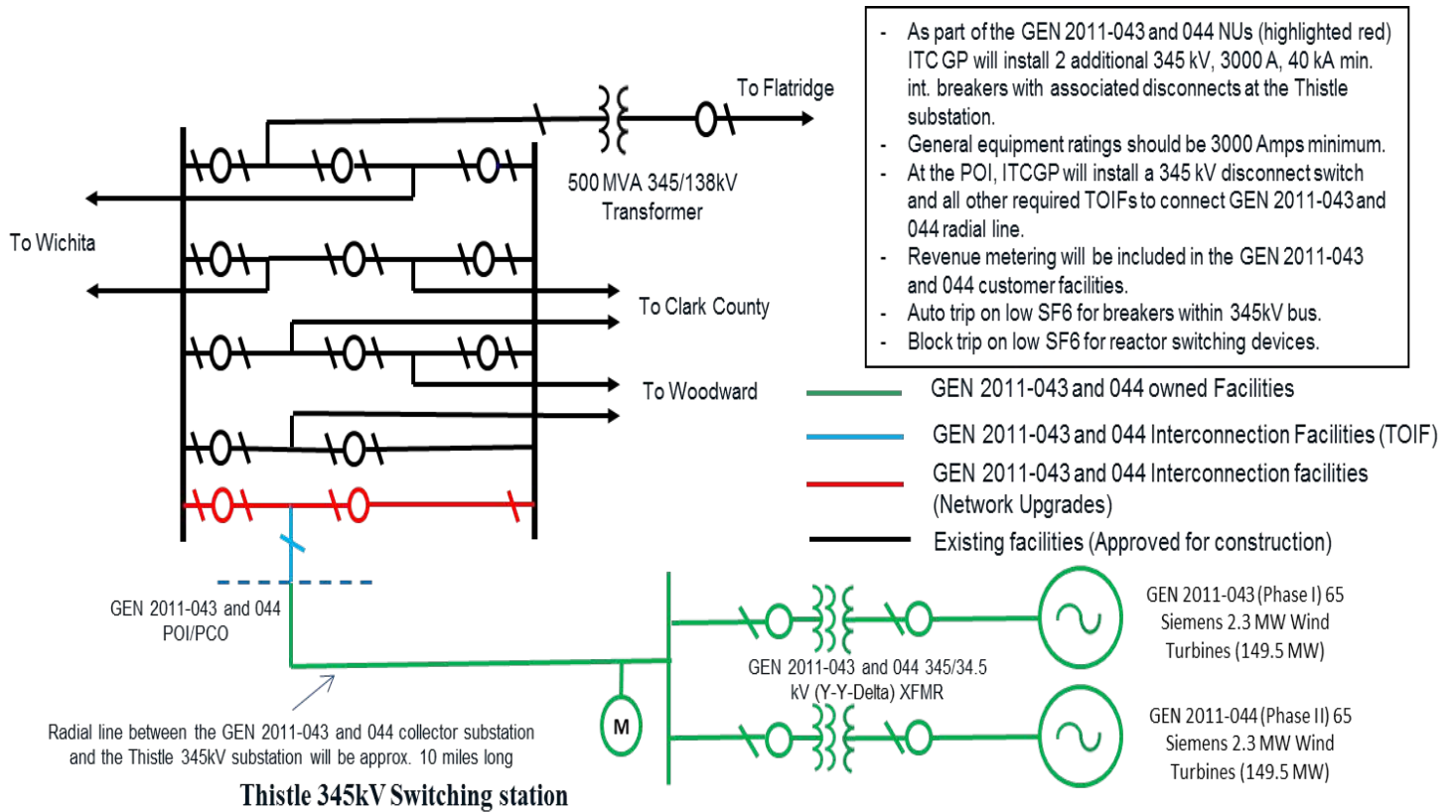

Figure 1 GEN-2011-044 ITCGP Thistle 345kV substation one line diagram

3.0.5 Site Plan:

See Figure 2 for site plan of Transmission Owner switching station at the POI at the Thistle 345kV substation. The equipment that needs to be added to accommodate the customer's interconnection request is clouded in red.

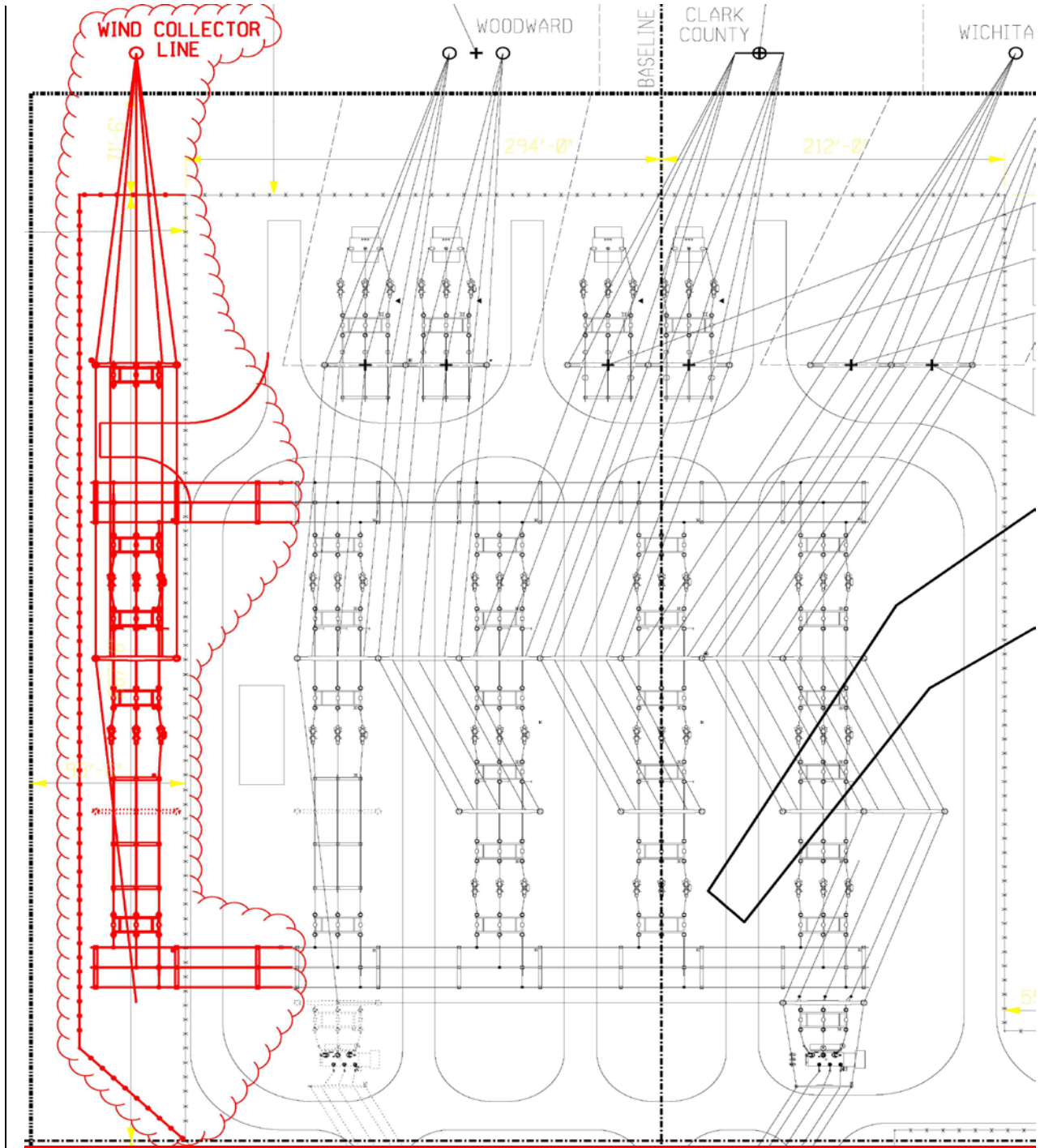

Figure 2 GEN-2011-044 ITCGP Thistle Interconnection substation site plan

3.0.6 Route Information: N/A

3.0.7 Right-of-Way Information:

It is assumed that the interconnection customer will be responsible for building the 345 kV line required to connect the ITCGP Switching Station at the POI with the customer's substation. As such, the interconnection costs contained herein do not include any costs for extending the ITCGP transmission line. Please see section 6 for general guidelines.

3.0.8 Permitting:

The Interconnection Customer will be responsible for satisfying all community or governmental site plan or zoning approval requirements which may include wetland or flood plain permits. The Transmission Owner will be responsible for the control center building permit and the KDHE storm water construction permits associated with the Transmission Owner portions of the construction.

3.0.9 Metering & Ownership Demarcation:

Covered in section 4.0.9

3.0.10 Protection & Control Overview:

Two 345kV breaker control panels with microprocessor based relays will be installed. Breaker failure protection, automatic reclosing supervised by synchronism check will be provided.

3.0.11 Insulation Coordination:

345kV, 1050kV BIL

3.0.12 Short Circuit Study Results - Bus Fault Levels:

ITCGP calculated bus fault levels for the interconnection substation and adjacent substations to determine if the added generation will cause fault currents to exceed interrupting ratings for existing equipment and for use in sizing future equipment. Calculations are based on data for the interconnection transformer and installed wind turbines supplied by the Interconnection Customer. Variance from supplied data could materially change calculated short circuit values. Results are displayed in Table 1.

Table 1 – Short Circuit Results

Fault Location	Maximum Fault Current (Amps)*	
	Phase	Ground
Clark County 345kV substation	14259.1	15789.3
Thistle 345 kV substation	15804.7	9978.5
Flatridge 138kV substation	16138.3	12853

Fault currents shown in Table 1 are within the circuit breaker interrupting capabilities with the addition of 299 MW contributed by both GEN-2011-043 and GEN 2011-044.

3.0.13 Reactive Compensation:

ITCGP evaluated the impact of the proposed interconnection on the reactive compensation equipment presently planned or in service for the Thistle substation facilities. ITCGP studies concluded that there was no requirement for additional reactive compensation at the Thistle substation for the addition of the combined 299 MW of both GEN 2011-043 and GEN 2011-044.

3.0.14 Other Equipments & Materials:

- Gas Circuit Breakers (GCB): Two (2) 345 kV, 3000A rated, 63kAIC.
- Disconnect Switch: Four (4) 345 kV, 3000A rated, 1050 kV BIL.
- Insulators: Twenty Seven (27) 345 kV, 1050 kV BIL station post, porcelain.
- Control Cable: Control cables per Transmission Owner standards will be installed in direct buried PVC conduits, above grade LFMC conduits and in pre-cast cable trench. All control cables from the yard will be terminated at the relaying control panels. The control building will have overhead cable trays for necessary cable runs and inter-panel connections.

3.0.15 Relaying, Control, & SCADA:

Panel Requirements

- 2 – RD3024 –Breaker Control (SEL-351S)
- 1 – Synch Panel

3.1.16 Grounding System:

The grounding system will be designed and installed per Transmission Owner’s standards. These standards follow the IEEE 80 standards.

3.0.17 Lightning Shielding Design:

Lightning shielding will be provided per Transmission Owner’s standards. Multiple H-frame structures along with shield wire and a lightning mast will be used for lightning protection.

3.0.18 Yard Lighting:

Yard lighting will be installed to be sufficient for visual indication of the disconnect switch positions or egress of personnel, and will not serve as task lighting.

3.0.19 Structures:

The required new outdoor steel structures listed below will be hot-dipped galvanized wide flange structures or tubular steel:

- Four (4) 345 kV disconnect switch stands
- Nine (9) 345 kV bus supports

3.0.20 Foundations:

Foundations and slabs will be designed and installed in accordance with the owner’s standards and specifications. The minimum design depth to firm bearing is contingent upon soil borings at the site.

3.0.21 Scheduling Requirements:

Legal/Real Estate Procurement	9 weeks
Material Procurement / Design	52-68 weeks
Substation Construction	32 weeks
Closeout Activities	4 weeks

3.0.22 Site Work:

Site grading will be required for the new 345kV switchyard.

3.0.23 Total Cost of Network Upgrades: 3,281,619

Total Cost Estimate Accuracy: +/- 20%

Note that the cost estimate provided is expressed in 2013 terms and includes applicable company overheads and potential tax gross ups.

4.0 Transmission Owner Interconnection Facilities

4.0.1 Project Location:

The generation facility will interconnect at the Thistle substation located in Barber County, Kansas.

4.0.2 Project Overview:

A new line entrance structure will be added at the Thistle substation for termination of the line from the collector substation. A disconnect switch will be installed beneath this structure for isolation of the developer's line. Line relaying will be added to protect the line. A set of CCVT's and surge arresters will be added to the line terminal.

4.0.3 Design Criteria:

The Transmission Owner's standards will be applicable. Where no applicable standards are available, the Transmission Owner will substitute industry standards and other good utility practices.

4.0.4 One-Line Diagrams: See Figure 1

4.0.5 Site Plan: See Figure 2.

4.0.6 Route Information: N/A

4.0.7 Right-of-Way Information: N/A

4.0.8 Permitting: Same as that covering section 3.0.8

4.0.9 Metering & Ownership Demarcation:

The Interconnection Customer or others will provide, own, operate and maintain revenue metering. The specifics of the revenue metering will be defined during the detailed engineering phase of the project. The customer must cooperate with the Transmission Provider and local Transmission Owner requirements in the metering design. Revenue metering equipment will be required at customer's project substation with loss compensation to the Point of Interchange in the Transmission Owner's substation.

The ownership demarcation will be at first substation steel H-frame within the security fence of the Transmission Owner substation.

The Interconnection Customer will be required to provide enough conductor to terminate on the H-frame and extend down to reach grade level.

4.0.10 Protection & Control Overview:

- One set of 345kV CCVTs will be installed on the Gen 2011-044 line.
- Two paths of fiber optic cable (OPGW) will be required for line protection. They will be supplied by the Interconnection Customer.
- One 345kV line relaying panel with microprocessor based relays will be installed.

4.0.11 Insulation Coordination:
345kV, 1050kV BIL

4.0.12 Short Circuit Study Results - Bus Fault Levels: See Section 3.0.12 above

4.0.13 Other Equipments & Materials:

- Disconnect Switch:
One (1) 345 kV, 3000A rated, 1050 kV BIL.
- CCVTs: Three (3) 345 kV, 3-winding, 1550kV BIL.
- Surge Arresters:
 - Three (3) 345 kV, vertical mount, 209 kV MCOV, polymer.
 - Control Cable
Control cables per Transmission Owner standards will be installed in direct buried PVC conduits, above grade LFMC conduits and in pre-cast cable trench. All control cables from the yard will be terminated at the relaying control panels. The control building will have overhead cable trays for necessary cable runs and inter-panel connections.

4.0.14 Relaying, Control, & SCADA:

Panel Requirements: One RD3048 Panel – Fiber optic current differential (SEL 311L Relays)

4.0.15 Grounding System:

The grounding system will be designed and installed per Transmission Owner's standards. These standards follow the IEEE 80 standards.

4.0.16 Lightning Shielding Design:

The attachment of the OPGW shield wire from the developer's line to the H-frame will provide lightning protection for the Interconnection Facility equipment at GEN 2011-043 interconnection substation.

4.0.17 Yard Lighting:

Yard lighting will be installed to be sufficient for visual indication of the disconnect switch position or egress of personnel, and will not serve as task lighting.

4.0.18 Structures:

The required new outdoor steel structures listed below will be hot-dipped galvanized wide flange structures or tubular steel:

- One (1) 345 kV disconnect switch stands
- Two (2) H-frame line entrance structures
- Three (3) 345 kV CCVT stands
- Three (3) 345 kV surge arrester stands

4.0.19 Foundations:

Foundations will be designed and installed in accordance with the owner's standards and specifications. The minimum design depth to firm bearing is contingent upon soil borings at the site.

4.0.20 Conductors, Shield Wires, & OPGW: N/A

4.0.21 Insulators: N/A

4.0.22 Removal of Existing Facilities: N/A

4.0.23 Site Work: N/A

4.0.24 Total Cost: \$ **741,713**

Total Cost Estimate Accuracy: +/- 20%

Total Project cost (Network Upgrades and Interconnection facilities): \$ 4,023,332

Note that the cost estimate provided is expressed in 2013 terms and includes applicable company overheads and potential tax gross ups.

5.0 Interconnection Customer Interconnection Facilities

All facilities within the Interconnection Customer's collector substation and between the Interconnection Customer's substation and ITCGP's Thistle substation are not included in this report and are the sole responsibility of the Interconnection Customer. Some of the key facilities are briefly mentioned below. The Point of Interconnection (POI) and the Point of Change of Ownership (PCO) are shown in Figure 1 above.

The Interconnection Customer shall construct an approximate 10 mile 345 kV radial line from the wind farm collector station to ITCGP's Thistle substation. Installation of OPGW shield wire on the radial line from GEN 2011-044 containing at least 12 single mode fibers will be required for ITCGP relaying and communication purposes.

The customer's step-up transformer between the wind farm's 34.5 kV collector network and the 345 kV facilities will require a high side breaker capable of interrupting a transformer high side winding fault.

All Interconnection Customer owned 345 kV apparatus as well as the revenue metering equipment located in the Interconnection Customer's substation shall comply with ITCGP standards and will be subject to ITCGP approval. ITCGP will provide the Interconnection Customer with standards during detailed design or upon request. The Interconnection Customer is solely responsible for the SCADA and telecommunications facilities necessary to operate and monitor its facility.

Necessary trip and close signal interlocks will be provided by ITCGP to the Interconnection Customer's generation facility for the safe operation of the system. Interconnection Customer will provide breaker status and current transformer signals to ITCGP for system operation and protection.

Total Project Cost: N/A

Total Cost Estimate Accuracy: N/A

6.0 Right Of Way Requirements

The Interconnection Customer shall obtain easements from the Transmission Owner to work in or drive through the Transmission Owner's transmission line right-of-way. The Transmission Owner and Interconnection Customer will also cooperatively negotiate any easements required for the Interconnection Customer's transmission lines and structures. The Transmission Owner agrees to not unreasonably withhold easements.

For the Network Upgrades and any Transmission Owner Interconnection facilities identified in this report, the Transmission Owner agrees to obtain all necessary easements/right-of-way as required to construct those facilities that will be owned and operated by ITCGP.